

TWR24/32-2R SERIES COMPACT RECEIVER PANELS

FEATURES

- 25 dB MINIMUM PORT TO PORT ISOLATION
- N OR BNC CONNECTORS
- 0.7 TO 2.5 dB TYPICAL NOISE FIGURE
- MODULAR DESIGN
- VHF-LOW/HIGH, UHF, 700/800/900 TRUNKING
- NO TUNING REQUIRED
- ONLY 2 RU (3.5")

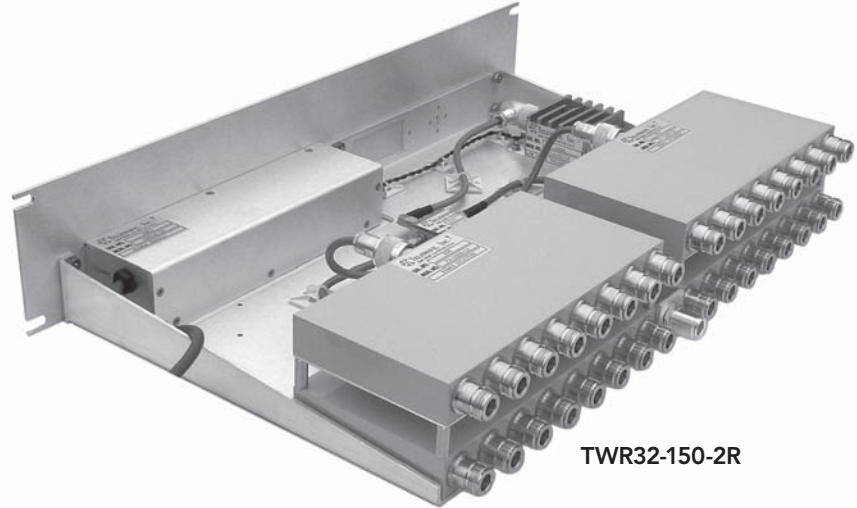

TWR32-150-2R

Telewave Compact Receiver Distribution Panels are used at medium to high density sites to feed multiple receivers from a common antenna, reducing cost and tower loading, while providing consistent signal quality, output isolation, and higher output levels. A typical receiver distribution panel includes a power supply, inline low noise preamplifier, and one or two 8-way splitters all on a single 19" tray. The preamplifier provides as much as +12 dB system gain to overcome splitting and cable losses.

Telewave 2R panels provide full performance in only 2RU (3.5" x 19" W). All receiver panels are fully shielded, and each panel has sufficient bandwidth to cover an entire commercial or Public Safety band.

New panels can be directly coupled to existing panels without additional parts or tuning. Successful multicoupling generally requires some type of

filtering between the receiver panel and antenna. Telewave manufactures a wide range of high quality preselector systems for transmitters and receivers.

Telewave receiver panels use high-quality splitters which provide two, four, or eight 50 ohm balanced outputs from one input, with 20-30 dB of isolation between ports. The antenna port is tuned with a matching network to insure a balanced input. The output level at any splitter port will be down at least 3 dB from the input as a result of the split, and preamplification is usually required.

These units, with their specially designed power supply, can be powered from an AC or DC source. The internal DC input circuitry will allow the external input DC voltage to vary between +11.5 VDC to +15 VDC, while keeping the DC output voltage constant. This feature allows the preamplifier to perform at its rated gain, 1 dB compression point, and 3rd order intercept point. This design is especially suited for

battery, solar panels, and thermal generator sources. An external DC-DC converter allows operation from DC inputs as low as +9.5 VDC.

The 2R series ships standard with an inline low noise bipolar preamplifier. Optional items include PHEMT preamps for lower noise figure, high 3rd order intercept preamps for RF congested sites, redundant preamps for maximum reliability at remote sites, and broadband preamps for multi-band applications.

TWR24/32-2R SERIES

MODEL	FREQUENCY	PORTS	BANDWIDTH	GAIN
TWR24-030-2R	30-88 MHz	24	58 MHz	0-12 dB
TWR24-050-2R	50-512 MHz	24	400 MHz	0-12 dB
TWR24-150-2R	132-174 MHz	24	42 MHz	0-12 dB
TWR24-250-2R	216-250 MHz	24	34 MHz	0-12 dB
TWR24-350-2R	300-400 MHz	24	40 MHz	0-12 dB
TWR24-450-2R	400-512 MHz	24	40 MHz	0-12 dB
TWR24-760-2R	763-824 MHz	24	40 MHz	0-12 dB
TWR24-860-2R	806-960 MHz	24	40 MHz	0-12 dB
TWR32-030-2R	30-88 MHz	32	58 MHz	0-12 dB
TWR32-050-2R	50-512 MHz	32	400 MHz	0-12 dB
TWR32-150-2R	132-174 MHz	32	42 MHz	0-12 dB
TWR32-250-2R	216-250 MHz	32	34 MHz	0-12 dB
TWR32-350-2R	300-400 MHz	32	40 MHz	0-12 dB
TWR32-450-2R	400-512 MHz	32	40 MHz	0-12 dB
TWR32-760-2R	763-824 MHz	32	40 MHz	0-12 dB
TWR32-860-2R	806-960 MHz	32	40 MHz	0-12 dB

COMMON SPECIFICATIONS	
Impedance / VSWR (typ.)	50 ohms / 1.3:1
Isolation port to port (min / typ.)	30-174 MHz: 20 dB / 25 dB 216-960 MHz: 25 dB / 30 dB
Noise figure (typ)	2.5 dB
Intermodulation (typ)	-130 dB for -30 dBm input
Third order intercept	+36 dBm
Temperature range	-40°C to +60°C
Power requirements	AC 120 VAC (std.) 220/240 VAC (opt.) DC +11.5 to +15 VDC (regulated output) +12 to +24 VDC (direct to preamp)
Connectors	Input - N Female Output - N or BNC Female (opt.)
Dimensions (HWD) in. (cm)	3.5 x 19 x 11 (8.9 x 48.3 x 27.9)
Weight lb. (kg) 24 / 32 ch.	11 (5.0) / 13 (5.9)

NOTES

1. All unused ports must be terminated with 50 ohms. TWL-01 terminating resistor is available for this purpose.
2. Panel gain is measured from the input port to any output port. Gain is adjusted at the factory according to individual system requirements. Standard gain is 6 dB +/- 1 dB if not specified.
3. Tuning range and bandwidth vary depending on frequency band and system components.
4. Exact frequencies and system gain must be specified with order.