

## PASS-REJECT CAVITY AND DUPLEXER TUNING

### IMPORTANT:

All cavities and cavity-based devices are factory tuned to the exact frequencies indicated on the label. No further tuning or optimization is necessary. If frequency or insertion loss must be changed, Telewave recommends that the equipment be returned to the factory to ensure optimum performance. The instructions in this document are for use only if factory service is not practical.

### TEST EQUIPMENT MINIMUM REQUIREMENTS:

1. Calibrated RF signal generator with 0 dBm output.
2. Calibrated frequency counter or meter.
3. Calibrated RF indicator such as a network analyzer or spectrum analyzer, with sensitivity of at least 80 dB below the RF generator output.

Tools required: 7/16" wrench and nut-driver, medium and small flat-blade screwdrivers.

*NOTE: When transmitter power is passing through a cavity, high RF voltages and currents exist on the internal surfaces. Cavity tuning should be performed using a signal generator only. If no other RF source is available, use the lowest output power available and make only minimal adjustments.*

### 1. TUNING THE PASS FREQUENCY

- A. Adjust the signal generator to the desired pass frequency at 0 dBm output.
- B. Connect the signal generator to one side of the cavity "T" connector, and the monitor or analyzer to the other side.
- C. Loosen the 7/16" locking nut on the center tuning shaft, and tune the shaft of the cavity for maximum response as indicated on the analyzer.

### 2. TUNING THE REJECT FREQUENCY

- A. Adjust the signal generator to the desired reject frequency at 0 dBm output.
- B. Connect the signal generator to one side of the cavity "T" connector, and the monitor or analyzer to the other side.
- C. Tune the capacitor for maximum attenuation of the output signal, as indicated on the analyzer.

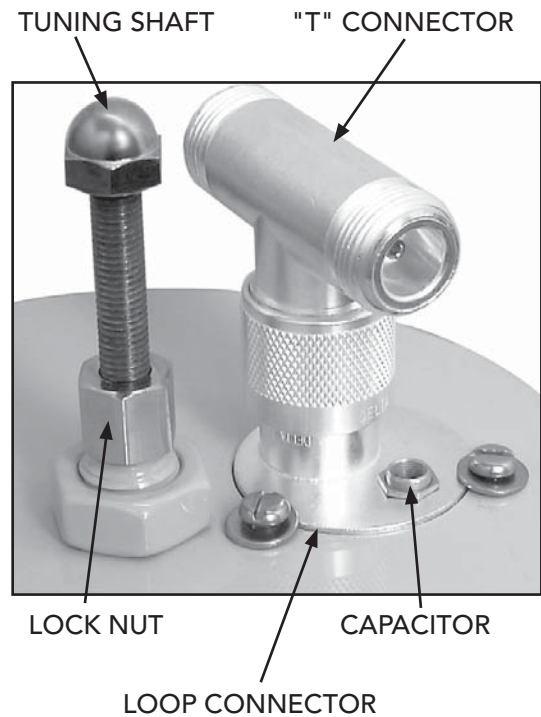

# PASS-REJECT CAVITY AND DUPLEXER TUNING

## 3. INSERTION LOSS ADJUSTMENT

- A. Adjust the signal generator to the desired pass frequency at 0 dBm output.
- B. Loosen the three retaining screws around the loop connector. Rotate the loop until the analyzer indicates the desired insertion loss. Tighten the retaining screws, and repeat Steps 1 and 2. An increase in the insertion loss will also increase the attenuation at the reject frequency. Minimum insertion loss occurs when the capacitor is on the opposite side of the connector, away from the center tuning rod.

*NOTE: All tuning adjustments are mutually dependent. This means that when you adjust the capacitor, the insertion loss will change and the loop position may have to be readjusted. The center tuning may have changed as well. Multiple adjustments will be required to achieve the best performance.*

## 4. PASS-REJECT DUPLEXER TUNING PROCEDURE

- A. Examine the labels on the top of the duplexer, and locate the TX and RX ports. The cavity set for TX will be PASS-TX and REJECT-RX. The cavity set for RX will be PASS-RX and REJECT-TX. If TX and RX are not marked, then you must determine which port is connected to the lower frequency device, and which is connected to the higher frequency device. The cavity set for the low frequency device will be PASS-LOW and REJECT-HIGH. The cavity set for the high frequency device will be PASS-HIGH and REJECT-LOW.
- B. Tune one cavity at a time using Steps 1-3. The reject frequency of one set of cavities is always tuned to the pass frequency of the other set.

